

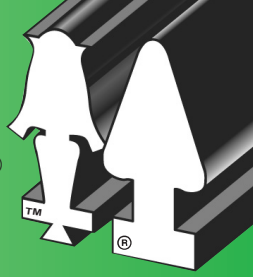

The Company With Connections®



THE NEXT LEVEL OF FLEXIBLE CONNECTORS

A-LOK® PREMIUM™ ASTM C-923 APPLICATION

A-LOK® PREMIUM™

Designed to produce a guaranteed watertight seal between pipe and concrete, the A-LOK® Premium™ flexible pipe-to-manhole connector provides maximum performance on the job site. Its unique design not only saves valuable project time, but also ensures longevity and offers unsurpassed environmental benefits.

A-LOK® Premium™ connectors prevent infiltration and ex-filtration into wastewater or stormwater systems, and are installed in the precast structure in a way that does not require coring or placement after the base component is cast. This eliminates residual waste from coring, disposal of the slugs or wasted raw material utilization or energy. Once cast-in, the connector becomes an integral component of the structure wall.

A-LOK® Premium™ has demonstrated in tests that it will meet and exceed 13 psi of hydrostatic water pressure.

MATERIAL

Extruded from compounds formulated for wastewater applications and engineered to conform to the requirements of section 4.1.1 of ASTM C-923, the standard rubber connector is available in alternative compounds upon request. Contact an A-LOK® representative regarding special applications, such as the presence of hydrocarbons.

KEY ADVANTAGES

The external appearance of the A-LOK® Premium™ connector appears to be a standard connector, but under differential loading or pipe deflection it will instantaneously react and redistribute its visco-elastic dynamic core material to maintain its circumferential sealing pressure. This visco-elasticity behavior is made possible by introducing a blend of environmentally friendly fibers, binders, polymers and congealing agents into the connector core which provides a controllable and dynamic viscous fluid within the connector. In most installations, this material will remain equally distributed throughout the core of the connector provided proper pipe bedding practices have taken place. In the event that short-term or long-term settlement of the pipe begins to occur, the core

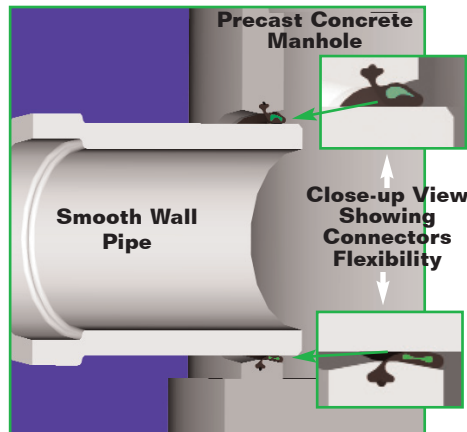

Cast in A-LOK® Premium™ Connector.
For all types of smooth wall pipe.

KEY ADVANTAGES (Continued)

material will react by redistributing and equalizing the blended materials to maintain its proper sealing compression.

A specific combination of fibers and congealing agents have been selected to prevent the escape or loss of material through absorption or from minor punctures or tears that could occur during the initial coupling of the connector and during its service life.

Benefits and advantages include:

1. Functioning on pure compression, the A-LOK® Premium™ allows for fast and easy field installation. After the pipe is beveled and the connector and pipe are cleaned and lubricated, the pipe is simply centered in the connector and inserted. Backfilling can be done immediately, thus enhancing project safety and overcoming the typical problems of water, running sand and other unstable trench conditions.
2. Efficient geometry of the profile lowers the coupling force required to insert the pipe into both radius and flat wall connector designs. Lower coupling force translates into quicker and easier installation.
3. Increased nominal pipe diameter tolerance over conventional compression connector designs while still maintaining up to 10 degrees of omnidirectional axial deflection.
4. Dynamic self-sealing core material can compensate for changes in dimensions and physical eccentricity.
5. Available in a range of sizes from 12" through 90" utilizing existing A-LOK® mandrels.
6. Backed by standard A-LOK Watertight Guarantee.
7. Like other A-LOK® connectors on larger-diameter pipe where size prohibits a gasket from being installed in a flat plane, the A-LOK® Premium can be configured for casting in a curve with the connector staying perpendicular to the center line of the pipe. Discovered through years of extensive research and development, this configuration causes no loss of compression or deflection.

PRODUCT REFERENCES

A.) ASTM C-923

Resilient Connector Between Reinforced Concrete Manholes Structures, Pipe and Laterals.

B.) ASTM C-1244

Standard Test Method For Concrete Sewer Manholes by the Negative Air Pressure (Vacuum) Test

C.) ASTM C-478

Standard Specification for Precast Reinforced Concrete Manhole Sections

PERFORMANCE STANDARD

The A•LOK® Premium™ connector is guaranteed to meet or exceed all material and test requirements outlined in ASTM C-923 "Resilient Connectors Between Reinforced Concrete Manhole Structures and Laterals".

Extruded from compounds formulated for wastewater applications, the rubber connector is engineered to conform to the requirements of ASTM C-923. Alternative compounds are available upon special request.

RESILIENT TEST REQUIREMENTS OF A.S.T.M. C-923

TEST	RESULTS	ASTM METHOD
Chemical resistance 1 N Sulfuric acid 1 N Hydrochloric Acid	no weight loss no weight loss	at 22°C for 48h
Tensile strength	1200 psi or 8.5 MPa, min	D 412
Elongation at break	350% min.	
Hardness	±5 from mfg's. specified hardness	D 2240 (Shore A durometer)
Accelerated oven-aging	decr. of 15%, max. of original tensile strength, decr. of 20% max. of elongation	D 573, 70±1°C for 7 days
Compression set	decr. of 25%, max. of original deflection	D 395, Method B, at 70°C for 22h
Water absorption	increase of 10%, max. of original by weight	D 471, immerse 0.75 by 2-in. or 19 by 25-mm Specimen in distilled water at 70°C for 48h
Ozone resistance	rating 0	D 1171
Low-temp brittle point	no fracture at -40°C	D 746
Tear resistance	200 lbf/in. or 34 kn/m	D 624, Method B

Copyright ASTM INTERNATIONAL. Reprinted with permission

DIMENSIONAL DATA

Maximum Pipe O.D. Based on Manhole Diameter and Pipe Angles Using A•LOK® Premium™ Connectors.

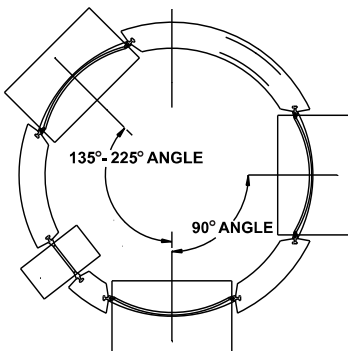

Min. distance between pipes is approx. 1/2 the smallest pipe OD

MAX. PIPE SIZE OD's

Manhole Diameter	135° - 225° Pipe Angle	90° Pipe Angle
42"	26.5"	22.0"
48"	31.5"	25.0"
60"	42.0"	32.0"
72"	52.5"	38.0"
84"	59.5"	44.0"
96"	73.5"	50.0"
108"	76.0"	56.0"
120"	87.5"	62.0"

PRODUCT SPECIFICATIONS

A flexible pipe to manhole connector shall be used whenever a pipe penetrates into a precast concrete manhole or structure. The connector shall be The A•LOK® Premium™ Connector as manufactured by A•LOK Products, Inc., Tullytown, PA or approved equal.

The design of the connector shall provide a flexible, watertight seal between the pipe and concrete structure. The connector shall assure that a seal is made between:

1. The connector and the structure wall by casting the connector integrally with the structure wall during the manufacturing process in a manner that it will not pull out during pipe coupling. The connector shall also be capable of being cast into a round structure by curving the connector in a manner that allows it to remain centrally located within the structure wall and perpendicular to the pipe. This configuration will result in no loss of seal or deflection of pipe entering a concrete structure.

2. The seal between the connector and the pipe shall be made by the compression of the connector between the outside circumference of the factory installed smooth oversleeve of a corrugated pipe or the smooth surface of a traditional pipe and the interior hole opening of the structure. The connector shall be the only component to affect the seal between the pipe and structure.

The connector shall be made from materials that conform to the physical and Section 4, "Materials and Manufacture" of ASTM C-923 Standard Specification for Resilient Connectors Between Reinforced Concrete Manhole Structures and Laterals", and the overall design will meet or exceed Section 7, "Test Methods and Requirements" of ASTM C-923. This connector shall be sized specifically for the type of pipe being used and shall be installed in accordance with the recommendations of the manufacturer.

IN THE FIELD PIPE INSTALLATION INSTRUCTIONS

STEP 1:

Confirm that the pipe surface is smooth, clean and free of foreign materials, chips, gouges and form seams due to manufacturing or handling. Slightly bevel any sharp or blunt edges caused by the cutting of the pipe.

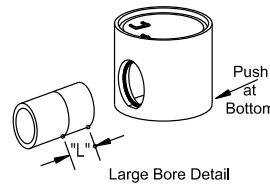

STEP 2:

Lubricate the connector and the entire section of the pipe that will be inserted into the connector. The chart below lists A-LOK's minimum lubrication length "L".

PIPE SIZE	MIN. LUBRICATION LENGTH "L"
8" - 15"	12"
16" - 18"	18"
21" & Larger	24"

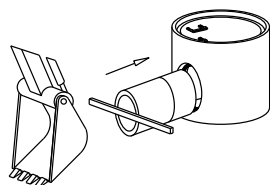

STEP 3:

Center the pipe and connector square to each other and insert the pipe into the connector using a bar or back hoe depending on the size. Once the pipe is coupled with the connector, deflect the structure or pipe to achieve the proper angle.

NOTE:

To find approximate subgrade, measure from the outside base of the structure to the junction of the connector and flat spot. Then add the wall thickness of the pipe plus 1/4 inch.

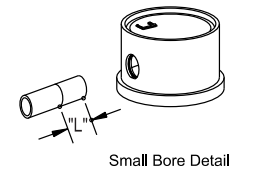

WARNING:

To ensure the A•LOK® Premium™ Connector remains a flexible watertight connector, it is A•LOK Products, Inc. strong recommendation that no mortar be placed between the pipe and wall of the concrete structure. The use of mortar in this area would decrease the effectiveness of the connector to compensate for shear caused by settlement or ground movement.

CAUTION:

When installing pipe stubs for future pipeline installation, all stubs must be properly restrained to prevent any movement by means other than the A•LOK® Premium™ Connector.

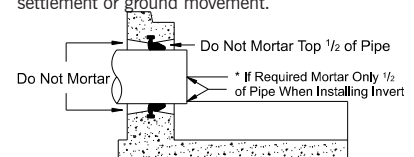



The Company With Connections®

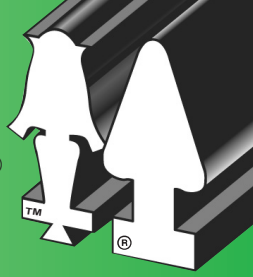

THE NEXT LEVEL OF FLEXIBLE CONNECTORS

A-LOK® PREMIUM™ ASTM F-2510 APPLICATION

A-LOK® PREMIUM™

The A-LOK® Premium™ is a flexible compression connector designed to be integrated into a watertight system based on ASTM F-2510. When used with a corrugated pipe with a factory installed smooth oversleeve or with a smooth wall pipe, the A-LOK® Premium™ will provide a guaranteed watertight seal between the pipe and the wall of a concrete structure. Its unique design not only provides maximum performance but saves valuable project time, extends the longevity of the structures and reduces the projects overall environmental impact.

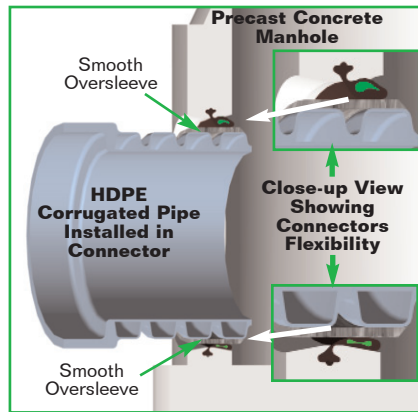

A-LOK® Premium™ Connector making a watertight connection with HDPE Corrugated Pipe using a factory installed smooth oversleeve.

A-LOK® Premium™ connectors prevent infiltration and ex-filtration about the pipe interface in wastewater or stormwater systems. They are installed in the structure in a way that does not require coring or placement as a secondary operation. This eliminates residual waste from coring, the disposal of the slugs, inefficient raw material utilization and excess energy use. Once cast-in, the connector becomes an integral component of the structure's wall.

MATERIAL

The connectors are extruded from rubber compounds that are formulated for wastewater applications and engineered to conform to the requirements of ASTM F-2510. The A-LOK® Premium™ connector is also available in alternative rubber compounds upon request. Please contact an A-LOK® representative regarding additional benefits and special applications, such as the presence of hydrocarbons.

DEFLECTION PERFORMANCE

Axial Deflection of Pipe (Angular) - 10 degrees

Outside Diameter of Pipe Deflection from Loading: 5% in accordance to ASTM F-2510

KEY ADVANTAGES

The external appearance of the A-LOK® Premium™ connectors appear to be a standard connector, but under differential loading or pipe deflection it will instantaneously react and redistribute its visco-elastic dynamic core material to maintain its circumferential sealing pressure. This visco-elasticity behavior is made possible by introducing a blend of environmentally friendly fibers, binders, polymers and congealing agents into the connector core which provides a controllable and dynamic viscous fluid within the connector. In most installations, this material will

KEY ADVANTAGES (Continued)

remain equally distributed throughout the core of the connector provided proper pipe bedding practices have taken place. In the event that short-term or long-term deflection of the pipe begins to occur, the core material will react by redistributing and equalizing the blended materials to maintain its proper sealing compression.

A specific combination of fibers and congealing agents have been selected to prevent the escape or loss of material through absorption or from minor punctures or tears that could occur during the initial coupling of the connector and during its service life.

A-LOK® Premium™ has successfully been tested to ASTM F-2510 deflection requirements of 5% without loss of seal.

Benefits and advantages include:

1. Functioning on pure compression, the A-LOK® Premium™ allows for fast and easy field installation. After the pipe is beveled and the connector and pipe are cleaned and lubricated, the pipe is simply centered in the connector and inserted. Backfilling can be done immediately, thus enhancing project safety and overcoming the typical problems of water, running sand and other unstable trench conditions.
2. Efficient geometry of the profile lowers the coupling force required to insert the pipe into both radius and flat wall connector designs. Lower coupling force translates into quicker and easier installation.
3. Increased nominal pipe diameter tolerance over conventional compression connector designs while still maintaining up to 10 degrees of omnidirectional axial deflection.
4. Connector can meet the 5% deflection requirements of ASTM F-2510 without loss of seal or compression. Dynamic self-sealing core material can compensate for changes in dimensions and physical eccentricity.
5. Available in a range of sizes from 12" through 90" utilizing existing A-LOK® mandrels.
6. Backed by standard A-LOK Watertight Guarantee.
7. Like other A-LOK® connectors on larger-diameter pipe where size prohibits a gasket from being installed in a flat plane, the A-LOK® Premium can be configured for casting in a curve with the connector staying perpendicular to the center line of the pipe. Discovered through years of extensive research and development, this configuration causes no loss of compression or deflection.

PRODUCT REFERENCES

- A.) **ASTM F-2510** – Standard Specification for Resilient Connectors Between Reinforced Concrete Manhole Structures and corrugated High Density Polyethylene Pipes.
- B.) **ASTM C-478** – Standard Specification for Precast Reinforced Concrete Manhole Sections.
- C.) **ASTM C-913** – Standard Specification for Precast Concrete Water and Wastewater Structures.

PERFORMANCE STANDARD

The A•LOK® Premium™ connector is guaranteed to meet or exceeds all material and test requirements outlined in ASTM F-2510 "Resilient Connectors Between Reinforced Concrete Manhole Structures and Corrugated High Density Polyethylene Drainage Pipes".

Extruded from compounds formulated for wastewater applications, the rubber connector is engineered to conform to the requirements of ASTM F-2510. Alternative compounds are available upon special request.

RESILIENT TEST REQUIREMENTS OF A.S.T.M. F-2510

TEST	RESULTS
Original Properties	
Tensile strength, min, psi (MPa)	1200 psi (8.3)
Elongation min, %	325
Hardness Type A durometer	40 to 60
Low-temperature hardness, Type A durometer, max increase, points	15
Compression set, max %	25
Ozone resistance	No cracks
Low Temperature Brittle Point	No Fractures -40°F (-40°C)
Tear Resistance lbf/in (kN/m), Die B	200 (34)
Accelerated Aging (Air Oven Test):	
Decrease in tensile strength, max % of original	15
Decrease in elongation, max % of original	20
Hardness, Type A durometer, max increase, points	8
After Water Immersion:	
Change in volume max %	5

Copyright ASTM INTERNATIONAL. Reprinted with permission

DIMENSIONAL DATA

Maximum Pipe O.D. Based on Manhole Diameter and Pipe Angles Using A•LOK® Premium™ Connectors.

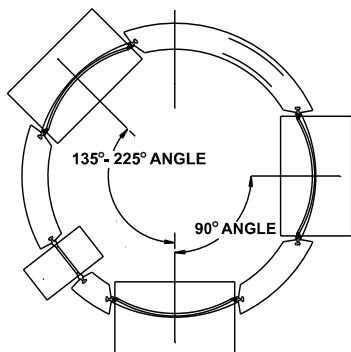

Min. distance between pipes is approx. 1/2 the smallest pipe OD

MAX. PIPE SIZE OD's

Manhole Diameter	135° - 225° Pipe Angle	90° Pipe Angle
42"	26.5"	22.0"
48"	31.5"	25.0"
60"	42.0"	32.0"
72"	52.5"	38.0"
84"	59.5"	44.0"
96"	73.5"	50.0"
108"	76.0"	56.0"
120"	87.5"	62.0"

PRODUCT SPECIFICATIONS

A flexible pipe to manhole connector shall be used whenever a pipe penetrates into a precast concrete manhole or structure. The connector shall be The A•LOK® Premium™ Connector as manufactured by A•LOK Products, Inc., Tullytown, PA or approved equal.

The design of the connector shall provide a flexible, watertight seal between the pipe and concrete structure. The connector shall assure that a seal is made between:

1. The connector and the structure wall by casting the connector integrally with the structure wall during the manufacturing process in a manner that it will not pull out during pipe coupling. The connector shall also be capable of being cast into a round structure by curving the connector in a manner that allows it to remain centrally located within the structure wall and perpendicular to the pipe. This configuration will result in no loss of seal or deflection of pipe entering a concrete structure.

2. The seal between the connector and the pipe shall be made by the compression of the connector between the outside circumference of the factory installed smooth oversleeve of a corrugated pipe or the smooth surface of a traditional pipe and the interior hole opening of the structure. The connector shall be the only component to affect the seal between the pipe and structure.

The connector shall be made from materials that conform to the physical and Section 4, "Materials and Manufacture" of ASTM F-2510 Standard Specification for Resilient Connectors Between Reinforced Concrete Manhole Structures and Corrugated High Density Polyethylene Drainage Pipes", and the overall design will meet or exceed Section 7, "Test Methods and Requirements" of ASTM F-2510. This connector shall be sized specifically for the type of pipe being used and shall be installed in accordance with the recommendations of the manufacturer.

INSTALLATION INSTRUCTIONS

STEP 1:

Confirm that the pipe surface is smooth, clean and free of foreign materials, chips, gouges and form seams due to manufacturing or handling. Slightly bevel any sharp or blunt edges caused by the cutting of the pipe.

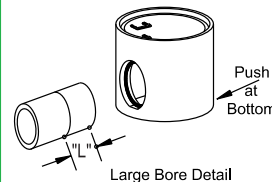

STEP 2:

Lubricate the connector and the entire section of the pipe that will be inserted into the connector. The chart below lists A-LOK's minimum lubrication length "L".

PIPE SIZE	MIN. LUBRICATION LENGTH "L"
8" - 15"	12"
16" - 18"	18"
21" & Larger	24"

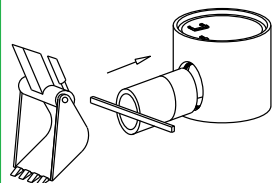

STEP 3:

Center the pipe and connector square to each other and insert the pipe into the connector using a bar or back hoe depending on the size. Once the pipe is coupled with the connector, deflect the structure or pipe to achieve the proper angle.

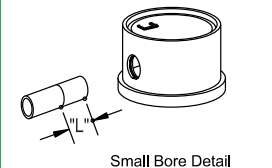

NOTE:

To find approximate subgrade, measure from the outside base of the structure to the junction of the connector and flat spot. Then add the wall thickness of the pipe plus 1/4 inch.

WARNING

To ensure the A-LOK® Premium™ Connector remains a flexible watertight connector, it is A-LOK Products, Inc. strong recommendation that no mortar be placed between the pipe and wall of the concrete structure. The use of mortar in this area would decrease the effectiveness of the connector to compensate for shear caused by settlement or ground movement.

CAUTION:

When installing pipe stubs for future pipeline installation, all stubs must be properly restrained to prevent any movement by means other than the A-LOK® Premium™ Connector.

