

NOTE:
FOR MANHOLES WITH A HEIGHT OF LESS THAN 10 FT, THE TOP CONE MAY BE REPLACED WITH A TOP SLAB.

SPECIFICATIONS:

- THE CONCRETE IS DESIGNED TO OBTAIN A STRENGTH OF 4,000 PSI IN 28 DAYS.
- THE REINFORCING STEEL HAS A YIELD STRENGTH OF 60,000 PSI.
- THE MANHOLE IS DESIGNED TO MEET THE REQUIREMENTS OF ASTM C-478, "PRECAST REINFORCED CONCRETE MANHOLE SECTIONS."
- THE REINFORCED CONCRETE STRUCTURE IS DESIGNED TO WITHSTAND AASHTO HS-20 LIVE LOAD CONDITIONS (DESIGN OF HATCH AND/OR FRAME AND COVER BY OTHERS).
- THE REINFORCED BASE SLAB IS DESIGNED FOR A MAXIMUM DEPTH OF 30 FT (DEPTH = F.G. TO TOP OF BASE SLAB).
- THE REINFORCED CONCRETE REDUCING SLAB IS DESIGNED FOR A MAXIMUM EARTH COVER OF 20 FT (EARTH COVER = F.G. TO TOP OF REDUCING SLAB).
- THE OPTIONAL A-LOK STORM GASKET IS DESIGNED TO MEET THE REQUIREMENTS OF ASTM C-1478, "STORM DRAIN RESILIENT CONNECTORS BETWEEN REINFORCED CONCRETE STORM SEWER STRUCTURES, PIPES, AND LATERALS."

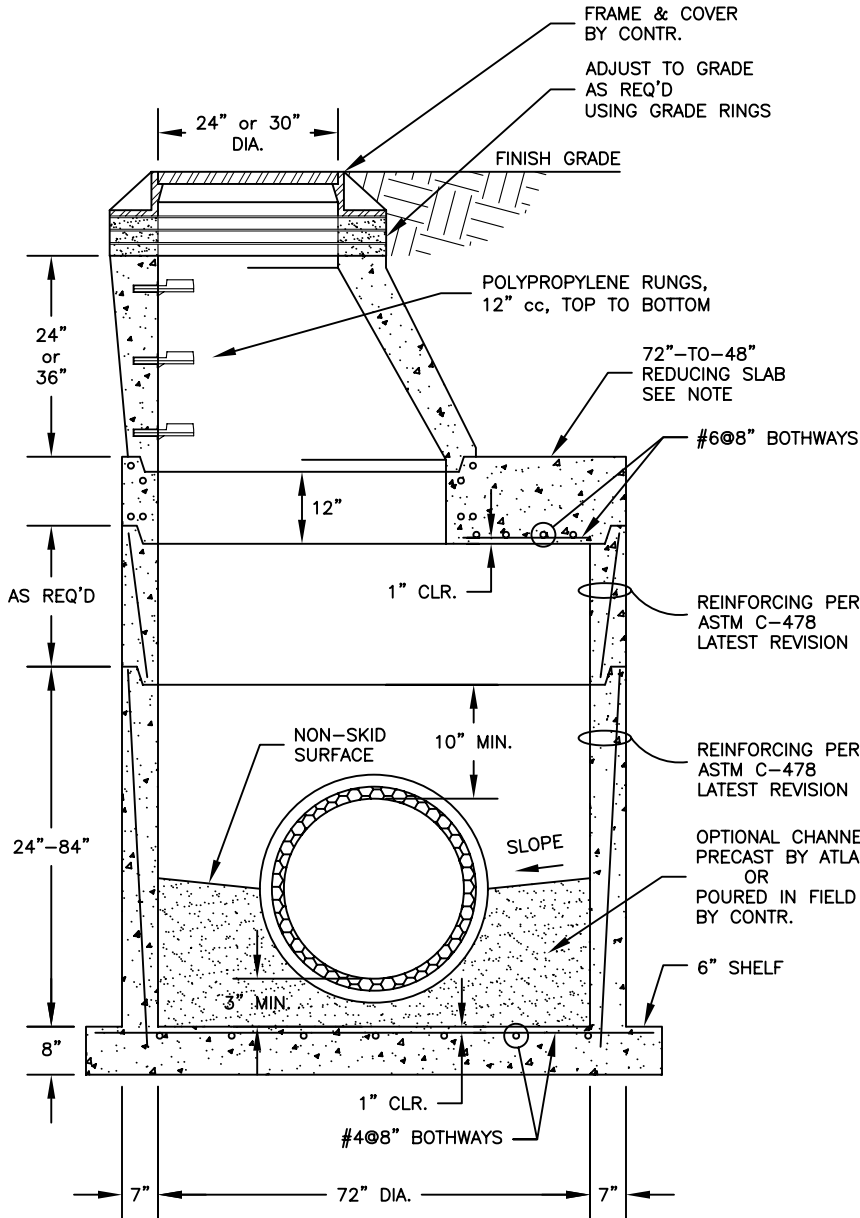

SECTION VIEW
NOT TO SCALE

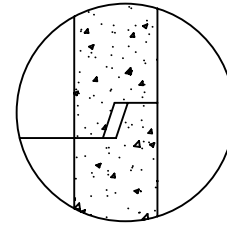

OPTIONAL SEAL:
BUTYL RUBBER
(ASTM C-990)

TYPICAL JOINT SECTION
NOT TO SCALE

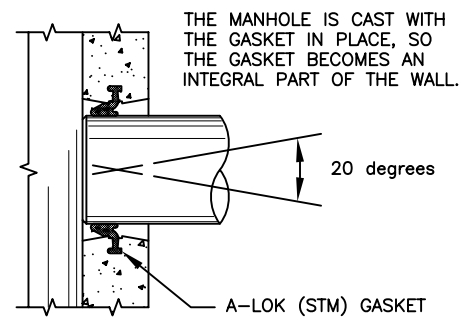

OPTIONAL A-LOK (STM) SECTION
NOT TO SCALE



ATLANTIC CONCRETE PRODUCTS, INC.
8900 Old Route 13
P.O. Box 129, Tullytown, PA 19007-7129
Phone: (215) 945-5600
Fax: (215) 946-3102
Web: www.atlanticconcrete.com

STORM MANHOLE
72" DIA.