

SPECIFICATIONS:

- THE CONCRETE IS DESIGNED TO OBTAIN A STRENGTH OF 4,000 PSI IN 28 DAYS.
- THE REINFORCING STEEL HAS A YIELD STRENGTH OF 60,000 PSI.
- THE MANHOLE IS DESIGNED TO MEET THE REQUIREMENTS OF ASTM C-478, "PRECAST REINFORCED CONCRETE MANHOLE SECTIONS."
- THE REINFORCED CONCRETE STRUCTURE IS DESIGNED TO WITHSTAND AASHTO HS-20 LIVE LOAD CONDITIONS (DESIGN OF HATCH AND/OR FRAME AND COVER BY OTHERS).
- A-LOK GASKETS ARE DESIGNED TO MEET THE REQUIREMENTS OF ASTM C-923, "RESILIENT CONNECTORS BETWEEN REINFORCED CONCRETE MANHOLE STRUCTURES AND PIPES."
- THE REINFORCED CONCRETE BASE SLAB IS DESIGNED FOR A MAXIMUM DEPTH OF 25 FT (DEPTH = F.G. TO TOP OF BASE SLAB).

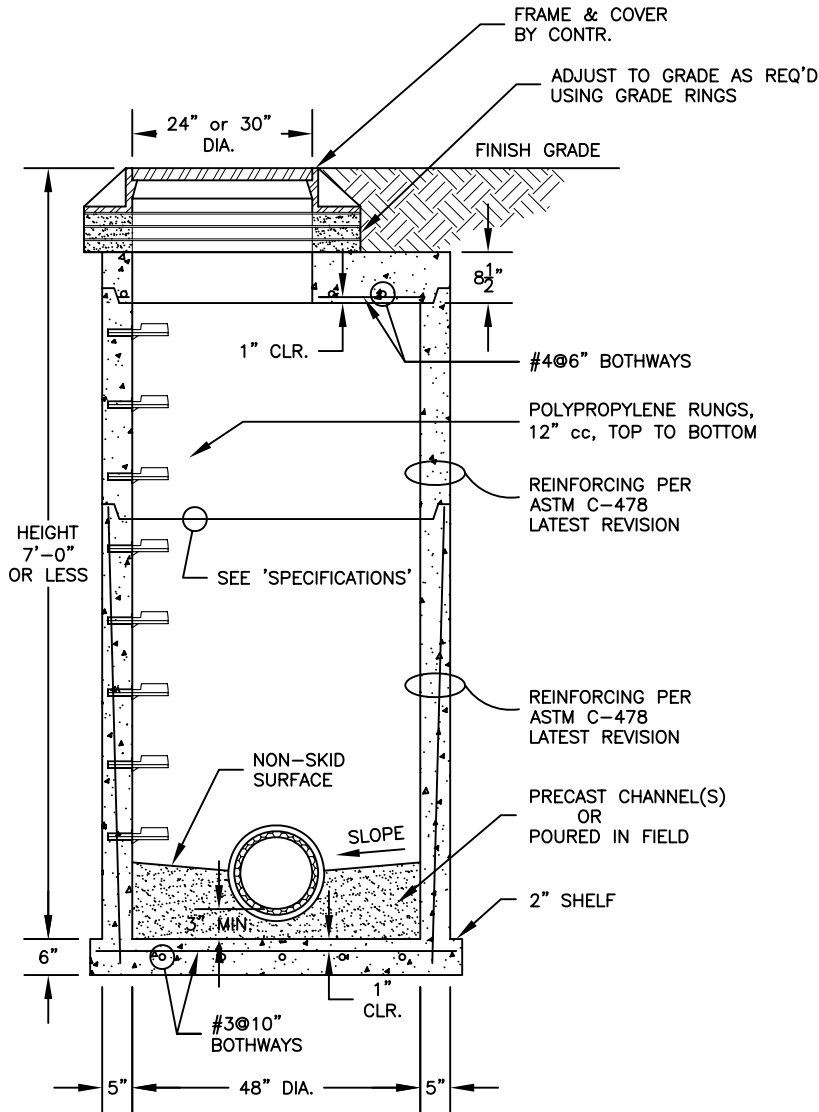

SECTION VIEW
NOT TO SCALE

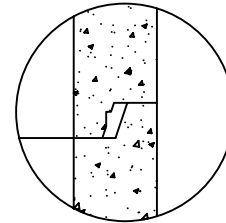

SEAL WITH BUTYL RUBBER (ASTM C-990) OR D-LOK RUBBER GASKET (ASTM C-443)

TYPICAL JOINT SECTION
NOT TO SCALE

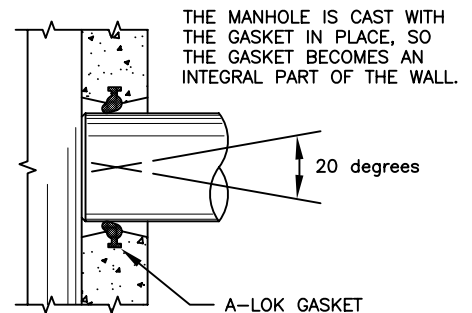

A-LOK (TYP.) SECTION
NOT TO SCALE



ATLANTIC CONCRETE PRODUCTS, INC.
8900 Old Route 13
P.O. Box 129, Tullytown, PA 19007-7129
Phone: (215) 945-5600
Fax: (215) 946-3102
Web: www.atlanticconcrete.com

SHALLOW MANHOLE
(4-FT DIA.)
WITH A-LOK SEAL