



The Company With Connections®



SLOTTED INSERT TO ANCHOR CAST IRON FRAME TO STRUCTURE

BOLT SLOT INSERT

A-LOK BOLT SLOT INSERT

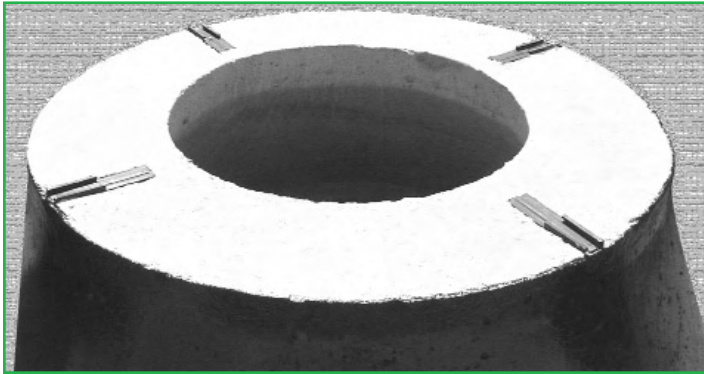

The **A-LOK BOLT SLOT INSERT** is a slotted insert designed to be cast into the conical or slab top section of underground concrete structures for the purpose of anchoring the cast iron frame to the structure. The insert assembly consists of a tough polypropylene shell and a .75 inch square galvanized nut.

The key purpose of the insert is to allow for center to center adjustment of the .75 inch galvanized nut to match the bolt center of the manhole frame. Traditional anchoring inserts require precise positioning on center to assure proper alignment of assembly. With the availability of the Bolt Slot Insert in overall lengths of 3 inches and 6 inches, any manhole frame can be accommodated regardless of bolt centers.

The inserts are shipped assembled for standard installation into the precast top section.

Inserts are held in position during the casting operation by a Four-Way Installation Holder in the four quadrants on a predetermined center to allow maximum adjustment in matching the bolt center of the manhole frame.

MATERIAL

The insert is molded from a copolymer polypropylene compound. The .75 inch square nut is galvanized.

KEY ADVANTAGES

- Guaranteed alignment of galvanized nut and bolt centers of manhole frame.
- The .75 inch square nut is galvanized to prevent corrosion.
- In traffic areas, misalignment of frame and structure top is eliminated due to shifting or movement during construction, or during routine maintenance.
- In easement areas, the frame assembly is protected against theft or vandalism by being firmly secured to the structure.
- Precast top sections can be standardized to accept any manhole frame regardless of bolt centers.

PRODUCT REFERENCES

A.) ASTM C-1244

Standard Test Method For Concrete Sewer Manholes by the Negative Air Pressure (Vacuum) Test

B.) ASTM C-478

Standard Specification for Precast Reinforced Concrete Manhole Sections

C.) FEDERAL REGULATION CODE RR-F-621

Specification for Frame, Covers, Gratings, Steps, Sump Catch Basins, Manholes

PART 6 • DIMENSIONAL DATA

PART NUMBER	LENGTH	INSERT ADJUSTMENT CAPABILITY
3 BOLT	3.125"	1.50"
4 BOLT	4.125"	2.00"
6 BOLT	6.125"	3.00"

4 Way Holder Detail (Part No.BSHDR)

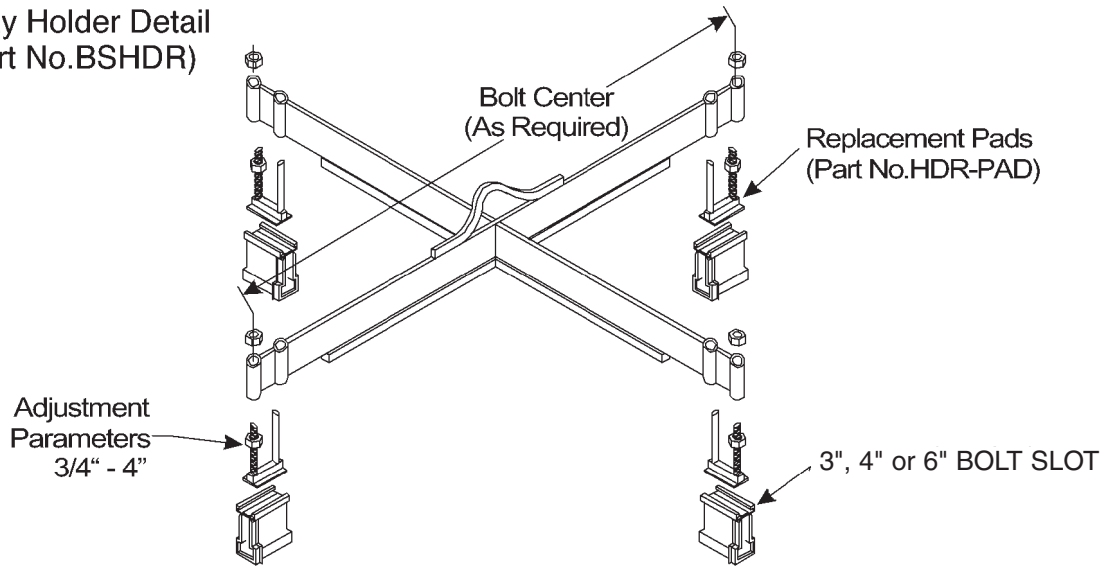

● INSTALLATION INSTRUCTIONS

PLANT INSTALLATION

1. Load Four-Way Installation Holder by sliding the (4) A•LOK BOLT SLOTS on to the Pads. Position each insert alike on the Pads to assure uniform placement in the precast section.
2. Pour concrete in form to desired level, and then press loaded Four-Way Installation Holder into concrete keeping common center of holder and core opening properly aligned.
3. When loaded holder and inserts have reached their proper position, use trowel to place concrete around inserts and finish top area.
4. When concrete has hardened, Four-Way Installation Holder and Pads can be removed.

FIELD INSTALLATION

1. Prior to placing the grade rings and manhole frame on the concrete structure, the sealing tab is removed from the top of the A•LOK BOLT SLOT to gain access to the .75 inch square nut.
2. An all thread rod is then threaded into .75 inch nut and adjusted to the proper center to match frame.
3. After the grade work and frame are in place, the top nuts are installed and tightened and excess rod is cut off.

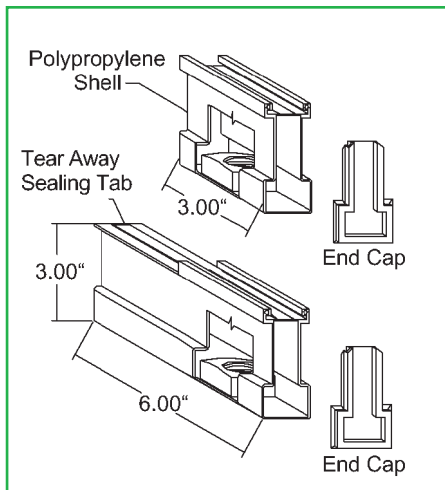

TYPICAL BOLT SLOT DETAIL

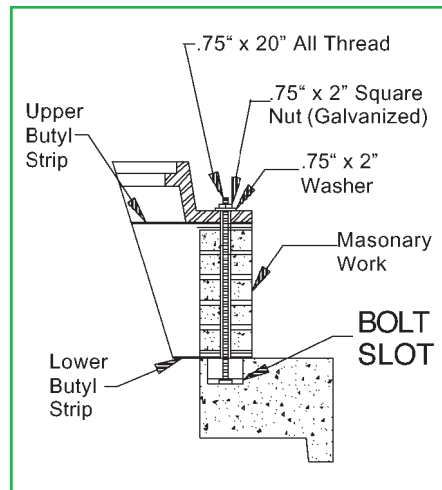

TYPICAL WATERTIGHT ASSEMBLY
(WITH GRADE WORK)

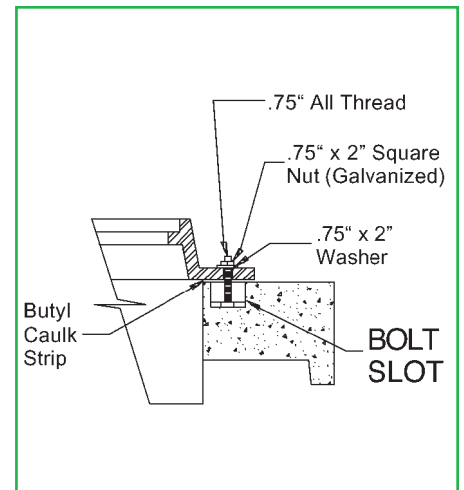

TYPICAL WATERTIGHT ASSEMBLY
(WITH NO GRADE WORK)

ANY QUESTIONS REGARDING A•LOK BOLT SLOT INSERT INSTALLATION, PLEASE CALL 1-800-822-2565