

**NOTE:**  
FOR MANHOLES WITH A HEIGHT OF LESS THAN 10 FT, THE TOP CONE MAY BE REPLACED WITH A TOP SLAB.

**SPECIFICATIONS:**

- THE CONCRETE IS DESIGNED TO OBTAIN A STRENGTH OF 4,000 PSI IN 28 DAYS.
- THE REINFORCING STEEL HAS A YIELD STRENGTH OF 60,000 PSI.
- THE MANHOLE IS DESIGNED TO MEET THE REQUIREMENTS OF ASTM C-478, "PRECAST REINFORCED CONCRETE MANHOLE SECTIONS."
- THE REINFORCED CONCRETE STRUCTURE IS DESIGNED TO WITHSTAND AASHTO HS-20 LIVE LOAD CONDITIONS (DESIGN OF HATCH AND/OR FRAME AND COVER BY OTHERS).
- THE REINFORCED BASE SLAB IS DESIGNED FOR A MAXIMUM DEPTH OF 30 FT (DEPTH = F.G. TO TOP OF BASE SLAB).
- THE REINFORCED CONCRETE REDUCING SLAB IS DESIGNED FOR A MAXIMUM EARTH COVER OF 10 FT (EARTH COVER = F.G. TO TOP OF REDUCING SLAB).
- A-LOK GASKETS ARE DESIGNED TO MEET THE REQUIREMENTS OF ASTM C-923, "RESILIENT CONNECTORS BETWEEN REINFORCED CONCRETE MANHOLE STRUCTURES AND PIPES."

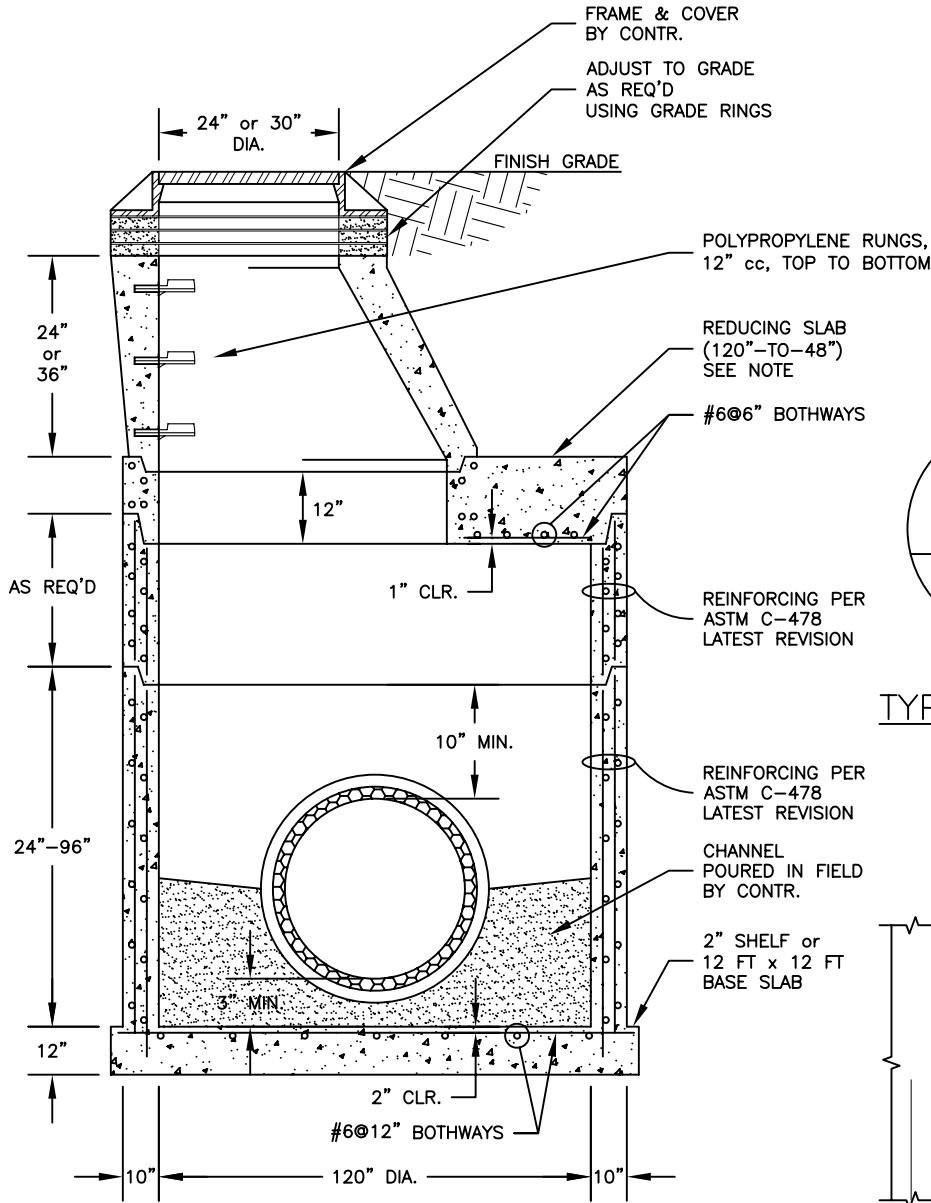

**SECTION VIEW**  
NOT TO SCALE

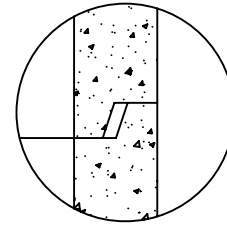

**TYPICAL JOINT SECTION**  
NOT TO SCALE

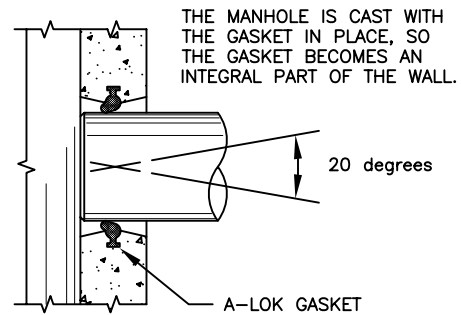

**A-LOK (TYP.) SECTION**  
NOT TO SCALE



ATLANTIC CONCRETE PRODUCTS, INC.  
8900 Old Route 13  
P.O. Box 129, Tullytown, PA 19007-7129  
Phone: (215) 945-5600  
Fax: (215) 946-3102  
Web: www.atlanticconcrete.com

120" DIA. MANHOLE  
WITH A-LOK SEAL  
(RECOMMENDED FOR PIPE SIZES 60"-66")